

ESCORTS K-10

Hydraulic Mobile Pick-n-Carry Crane of 10T Capacity



The New
Generation
Pick 'N' Carry
Crane

Pick 'n' Carry Crane K-10

SALIENT FEATURES :

- Front Mounted Cabin-Excellent Visibility, Drivability & Control
- Compact Dimension - High Maneuverability
- 3 Part synchronised boom - Large Working range and high lift duties
- Self Compensation Hook system
- New Technology Control Valve for Precision Handling

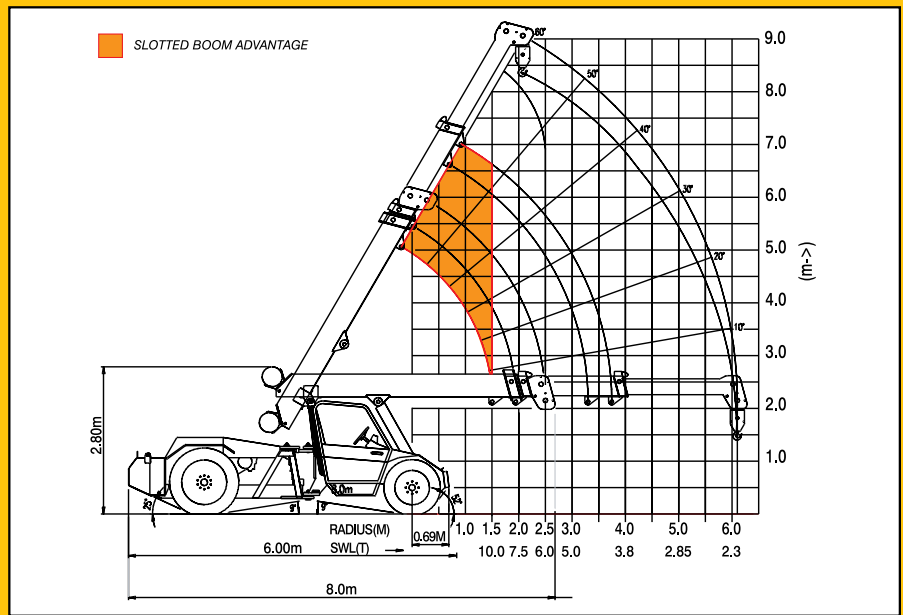

Specifications :

Engine	
Make & Model	Simpson S-433 Four Cylinder, Water Cooled Diesel Engine Rated power for crane 49 BHP @ 2200 RPM (Max continuous engine rating 59 HP @ 2300 RPM) or equivalent Engine
Transmission	
Type	Heavy duty transmission developed especially for crane application. Sliding Mesh, spur teeth gearbox. Six forward and two reverse speeds with high & low selector lever.
Speed	Travel Speed 25 Kmph - restricted as per safety norms (without load)
Clutch	Single plate, heavy duty dry friction type clutch plate especially designed for crane application.
Steering	
Type	Articulated power steering, through steering wheel
Articulation	45°
Turning Radius	5980 mm
Operational Timings (no load at rated engine RPM)	
Boom Raising	14-18 secs
Boom Lowering	8-12 secs
Telescopic Extension in	6-8 secs
Telescopic Extension out	8-10 secs
Hoist Line Speed	60m/min
Brakes	
Front Wheel	Pneumatically assisted hydraulic brakes
Rear Wheel	Mechanical shoe brakes actuated through hydraulic slave cylinder
Parking	Mechanically actuated on rear wheels
Track	
Front	1900mm(center of twin wheels)
Rear	1570mm(center of wheels)
Tyres	
Front	11.00x20-16PR(Four Nos.)
Rear	13.00x24-12PR(Two Nos.)
Aisle Width	2440 mm

Boom		
Telescoping	Three part Boom, Hydraulically telescopic synchronised	
Derricking	Through double acting jack.	
Hoist Mechanism		
Hoist	Four falls, Hydraulic winch, Fully compensated block with 8.4 m hook travel, safety brake on hoist. Rope dia 13mm	
Hydraulic System		
Pump	Pin Vane type hydraulic pump.	
Control Valve	3 spool control valve with built in pressure relief valve for precision handling	
Hydraulic Filter	Suction line has a 100 mesh inline strainer while return line has 25 microns full flow filter	
Electrical System		
Type	12V Single battery, Negative earth	
Capacities		
Fuel Tank	90 Ltrs.	
Hydraulic Tank	90 Ltrs.	
Weights		
Front Axle	3700 kgs.	
Rear Axle	6000 kgs	
Total (shipping)	9700 kgs	
Safety System		
• Safety brakes on hoist	• Hose protection failure device	
• Cylinder guard for protection	• Rope Compensation System	
Standard Accessories		
• All weather front mounted cabin	• Tools and tackle box	• Front Bumper
• Lift Cylinder Guard	• Cabin fan	• Reflectors
• Rear View Mirror	• Turn & Reverse lamp	
Optional Accessories		
• Overload warning system	• Fly jib 2.3m	• Fire Extinguisher
• Left hand drive	• Air conditioned cabin	• Spark Arrester
• Safe load indicator with hydraulic cut off		• Beacon Light



ESCORTS CONSTRUCTION EQUIPMENT LIMITED

Plot No: 219, Sector-58, Ballabgarh, Faridabad (Haryana) - 121 004, India

Tel.: (0129) 2306300/2306570, Fax: (0129) 2306463

E-mail: marketing@escorts-ecl.com, Website: www.ecl.com